



Gamesman

Esterline

Game Light Product Specification

Issue 03: Date 14.06.2017



Disclaimer:

The information provided within this product specification is intended only to make the reader aware of the product's technical data and its use thereof. As such, Gamesman Ltd shall not be held liable for any loss or damage to the assembly or component within, arising from its misuse or from the unintended use of information or particulars included within, or any omission from, this document.

Design and specifications are subject to change without notice.

Failure to observe the interface requirements specified in this document may result in damage to the electronics and resultant performance characteristics of the product.

1. Product Dimensions

a) General Dimensions

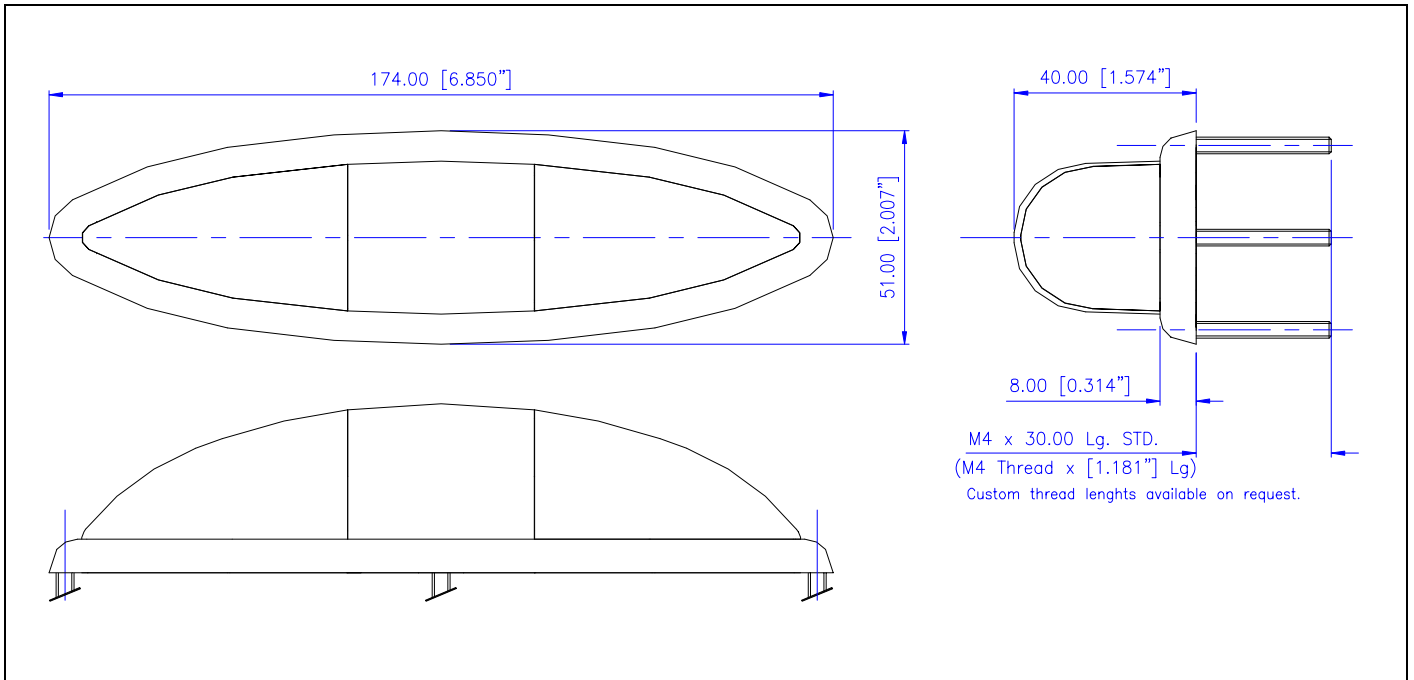

Standard threaded fixing length is 30.00mm;
Other lengths are available on request at 10.00mm & 15.00mm.
4 x M4 NYLOC Nuts required to fix the Game-light to the cabinet are not supplied -
1.5nM max torque when tightening to a panel.

b) Panel Cut Out Details

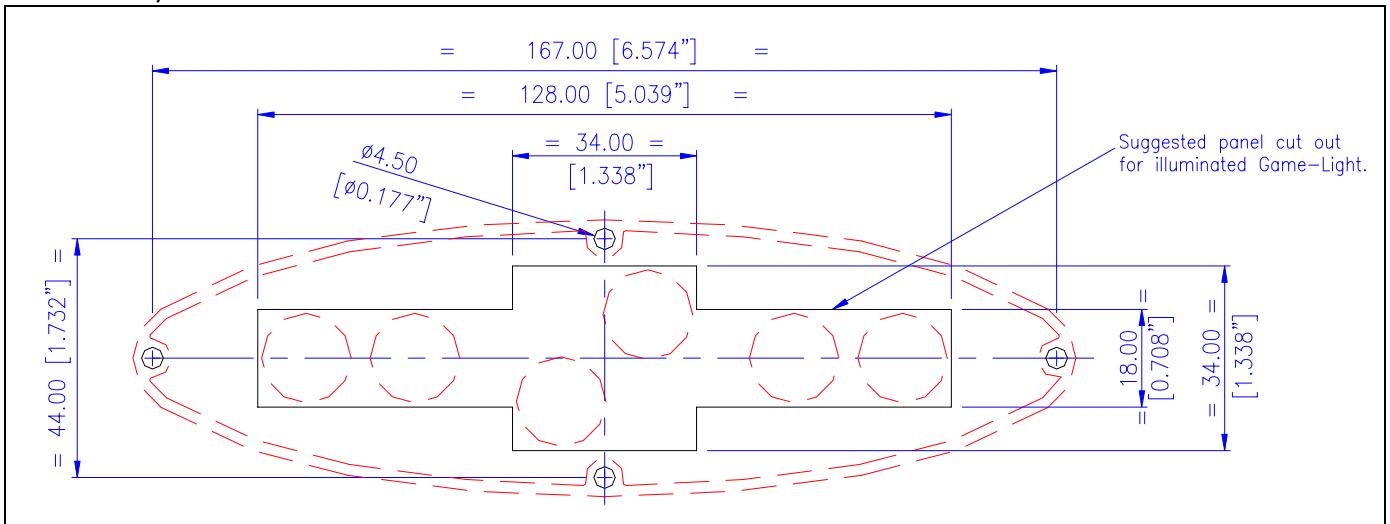

2. Product Identification

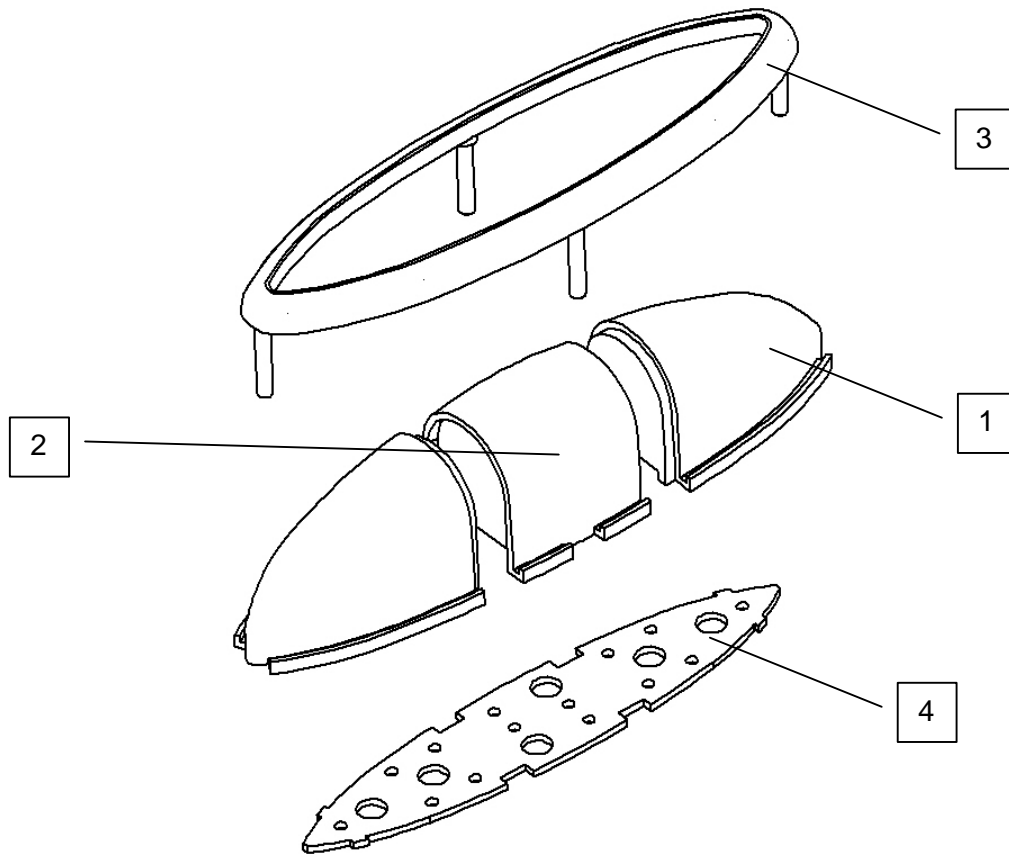

No.	Part Number	Description	Material	UL94 Rating
1	G3-472	End Lens	Polycarbonate See Note 1	V2
2	G3-473	Middle Lens	Polycarbonate See Note 1	V2
3	Various	Bezel See Note 2	Polycarbonate	V2
4	G4-682	Lamp Holder Plate	Polycarbonate	V2
5	Various	Harness See Note 3	N/A	N/A
6	Various	Lamp or LED See Note 3	N/A	N/A

Note 1. Component available in various colours, see specification sheet for the options.

Note 2. The Game light bezel comes as standard with threaded fixing studs of 30.00mm in length. Standard Bezel colour is black; or Chrome may be available subject to Lead Times and MOQ.

Note 3. The Game light is available in a number of harness configurations and with various Lamp and LED options, see section 3.

3. Product Compatibility

a) Harness options

Part Number	Description	Mating Connector	Schematic
G4-731	Sinking – 6 Way	AMP Connector 172339-1 and Terminals 170362-1 strip 170336-1 loose	
G4-705	Sourcing – 6 Way		
G4-1736	Sourcing – 4 Way	Molex PCB Mount 39-28-1043 (5566 Series) R/H PCB Mount 39-29-1048 or 39-30-1040 (5569 Series) Cable Mount 39-01-2041 (5559 Series) with Terminals 39-00-0041	

b) Lamps and LED's

Various lamps and LED options are available for the Game-light, it is possible in some cases to offer coloured Lamps or LED to match the colour of the various lens sections, where a lens/illumination colour match is not possible we will use a white Lamp or LED.

[Lamps Compatible with the Game Light](#)



[LED's Compatible with the Game Light](#)

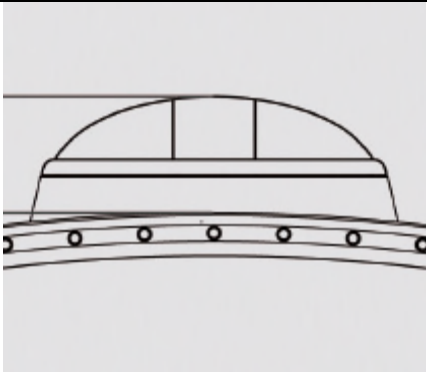

c) Tower Light Extension Piece

Part Number	Curve	Height	Image
GMP00868	R700.00	23.70	 <p>This extension moulding is compatible with the Gamesman Topper GT2000</p>

4. Specification Sheet

Download specification Sheet



Items that are shown in GREY are subject to MOQ

5. Packaging

Standard Packaging for the Game light:

Protected within a bubble wrap bag and placed in a box. Full box contains 25pcs (small box) or 50 pcs (large box).



GAMESMAN LTD
CROMPTON FIELDS, CROMPTON WAY, CRAWLEY, WEST SUSSEX, RH10 9QB
TEL: +44 (0) 1293 418888 FAX: +44 (0) 1293 418880

REGISTERED IN ENGLAND No. 3027138

Website: www.gamesman.co.uk

E-mail: sales@gamesman.co.uk